

BW Series

Area sensor

■ Features

- Long sensing distance up to 7M
- 22 types of products
(Optical axis : 20/40mm, Sensing height : 120~940mm)
- Increased sensing stability by minimizing the non sensing area
- Easy identification of the side, front and long distance with high luminance twin operation indicators
- Includes self-diagnosis function, mutual interference prevention function, external diagnosis function.
- Polished design & slim size (W28.6×H22.6×L□mm)
- IP65 rated waterproof structure (IEC standard)



⚠ Please read "Caution for your safety" in operation manual before using.



■ Specifications

Model	NPN open collector output (Standard type)	BW20-08	BW20-20	BW20-32	BW20-44	BW40-04	BW40-10	BW40-16	BW40-22
	PNP open collector output	BW20-08P	BW20-20P	BW20-32P	BW20-44P	BW40-04P	BW40-10P	BW40-16P	BW40-22P
Sensing type	Transmitted beam type								
Sensing distance	0.1 ~ 7m								
Sensing target	Opaque materials of min. ϕ 30mm				Opaque materials of min. ϕ 50mm				
Optical axis pitch	20mm				40mm				
Number of optical axis	8~48pcs				4~24pcs				
Sensing width	140~940mm				120~920mm				
Power supply	12~24VDC \pm 10% (Ripple P-P:Max. 10%)								
Protection circuit	Reverse polarity protection								
Current consumption	Emitter : Max. 80mA, Receiver : Max. 80mA								
Control output	<ul style="list-style-type: none"> • NPN open collector output \Rightarrow Load voltage:Max. 30VDC, Load current:Max. 100mA, Residual voltage:Max. 1VDC • PNP open collector output \Rightarrow Load current:Max. 100mA, Output voltage:Min. (Power supply-2.5)VDC 								
Operation mode	Light ON only								
Short-circuit protection	Includes								
Response time	Max. 12ms								
Light source	Infrared LED(850nm modulated)								
Synchronization type	Timing method by synchronous line								
Self-diagnosis	Ambient light monitoring, Emitter/Receiver light circuit monitoring, Output circuit monitoring								
Interference protection	Interference protection by master/slave function								
Ambient temperature	-10 ~ +55°C (at non-freezing status)								
Storage temperature	-20 ~ +60°C								
Ambient humidity	35 ~ 85%RH								
Storage humidity	35 ~ 85%RH								
Ambient illumination	Sunlight : Max. 10,000lx, Incandescent lamp : Max. 3,000lx								
Noise strength	The square wave noise by the noise simulator (Voltage: \pm 240V, Period:10ms, Pulse width:1 μ s)								
Dielectric strength	1,000VAC 50/60Hz for 1minute								
Insulation resistance	Min. 20M Ω (500VDC mega)								
Vibration	1.5mm amplitude at frequency of 10 ~ 55Hz in each of X, Y, Z directions for 2 hours								
Shock	500m/s ² (50G) in X, Y, Z directions for 3 times								
Protection	IP65 (IEC standard)								
Material	• Body : Aluminum • Front cover, Lens : Acrylic								
Accessory	Bracket A : 4EA, Bracket B : 4EA, Bolt : 8EA								
Unit weight	Approx. 1.4kg (For 48 optical axis)								

Area Sensor

Feature data

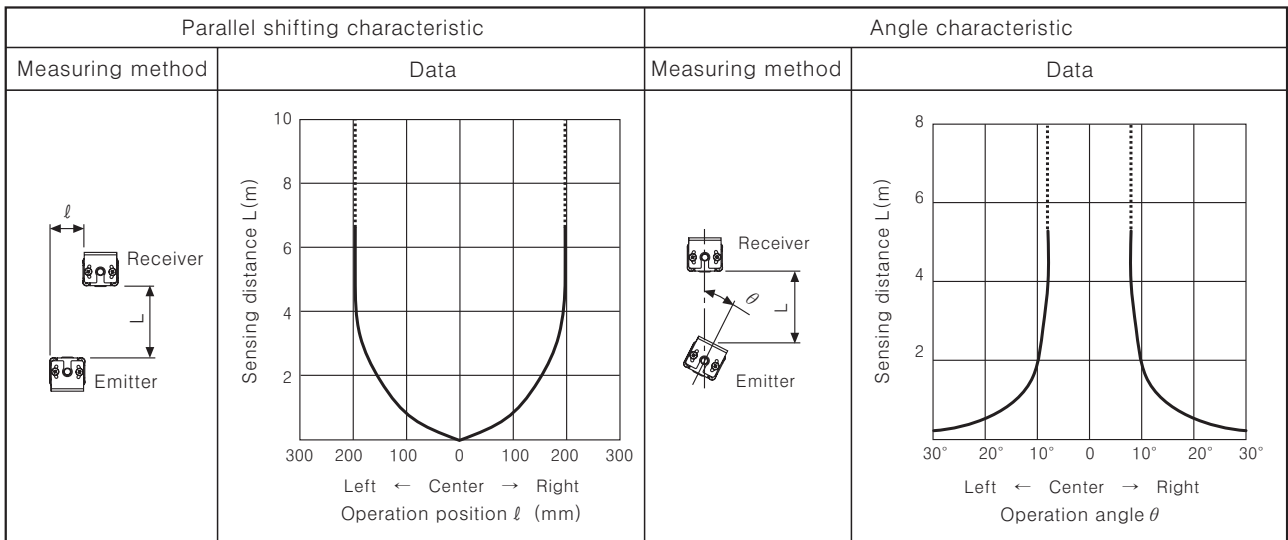

Dimensions

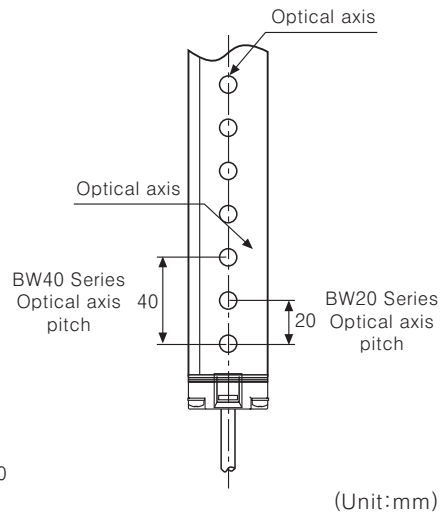
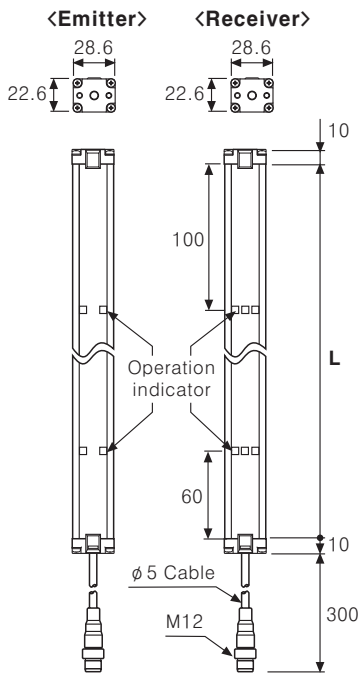

Model	L (mm)	Model	L (mm)
BW20-08(P)	160mm	BW20-32(P)	640mm
BW40-04(P)		BW40-16(P)	
BW20-12(P)	240mm	BW20-36(P)	720mm
BW40-06(P)		BW40-18(P)	
BW20-16(P)	320mm	BW20-40(P)	800mm
BW40-08(P)		BW40-20(P)	
BW20-20(P)	400mm	BW20-44(P)	880mm
BW40-10(P)		BW40-22(P)	
BW20-24(P)	480mm	BW20-48(P)	960mm
BW40-12(P)		BW40-24(P)	
BW20-28(P)	560mm		
BW40-14(P)			

●Bracket A

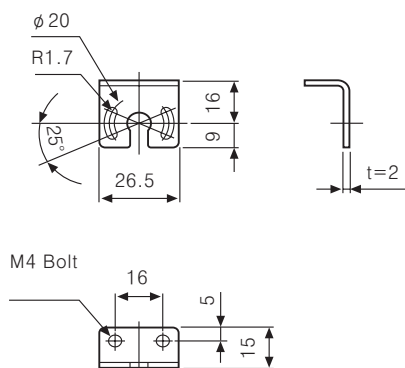

●Bracket B

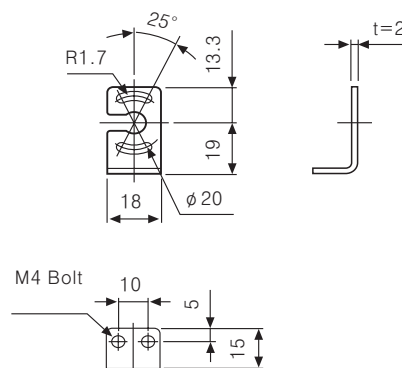

(Unit:mm)

(A) Counter

(B) Timer

(C) Temp. controller

(D) Power controller

(E) Panel meter

(F) Tacho/Speed/Pulse meter

(G) Display unit

(H) Sensor controller

(I) Switching power supply

(J) Proximity sensor

(K) Photo electric sensor

(L) Pressure sensor

(M) Rotary encoder

(N) Stepping motor & Driver & Controller

(O) Graphic panel

(P) Production stoppage models & replacement

BW Series

Input/Output circuit and connection diagram

●NPN open collector output type

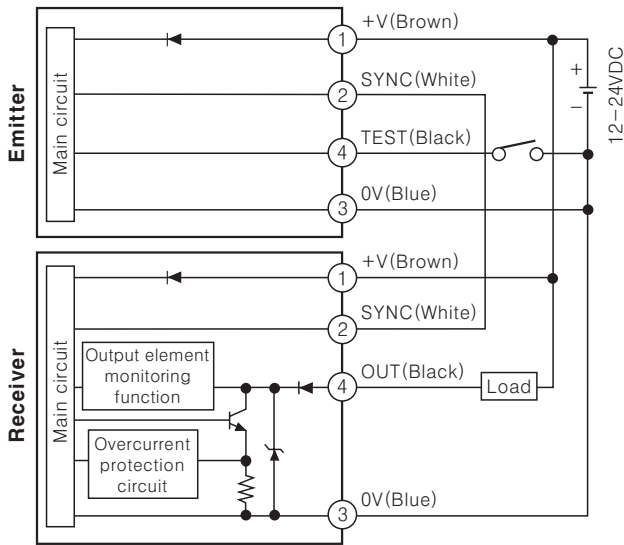

●PNP open collector output type

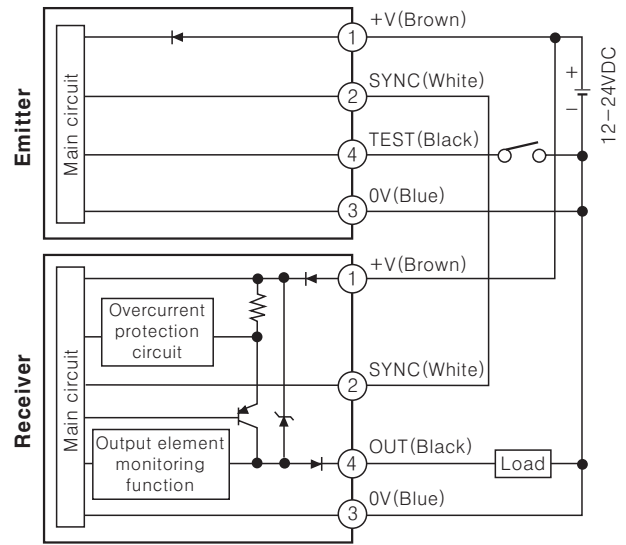

Structure

Upper operation indicator is set additionally, in case the number of the optical axes is more than 24pcs in BW20-Series and more than 12pcs in BW40-Series.

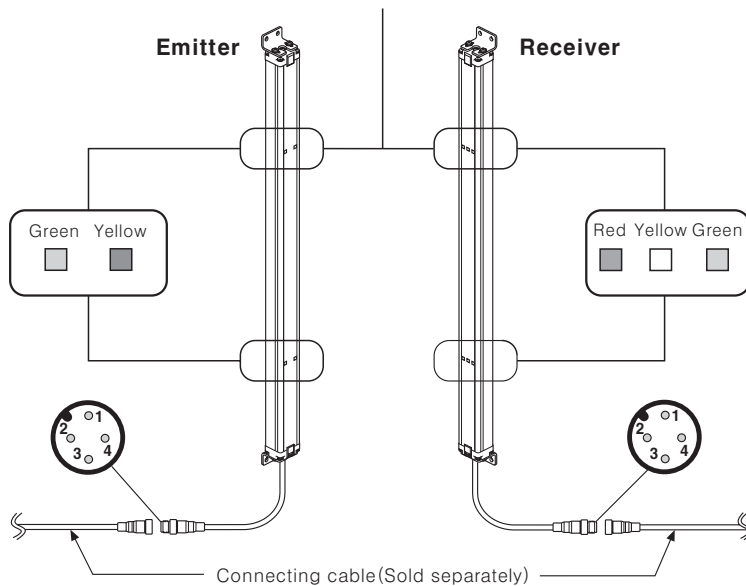

<Operation indicator >

LED color	Emitter	Receiver
Green	POWER	ON
Yellow	TEST (M/S)	UNSTABLE
Red	—	OFF

<Wiring Connection >

Pin No	Cable color	Emitter	Receiver
1	Brown	12-24VDC	12-24VDC
2	White	SYNC	SYNC
3	Blue	0V	0V
4	Black	TEST (M/S)	OUT

Connecting cable(Sold separately)

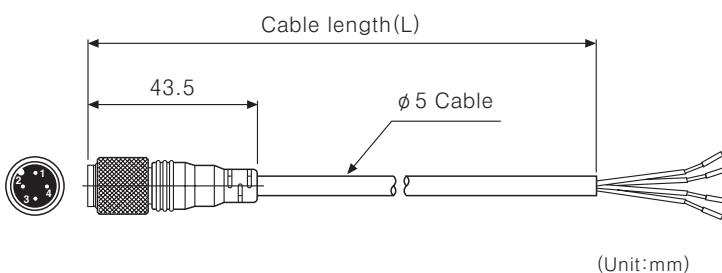

Model	Cable length(L)	Connector color
CID4-3-T CID4-3-R	3m	Emitter(T) : BLACK Receiver(R) : GRAY
CID4-5-T CID4-5-R	5m	
CID4-7-T CID4-7-R	7m	
CID4-10-T CID4-10-R	10m	

*Connecting cable is sold separately.

Area Sensor

Bracket mounting

●Bracket A

●Bracket B

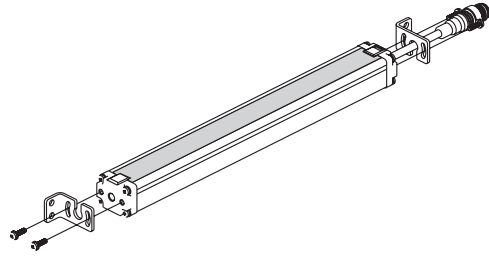
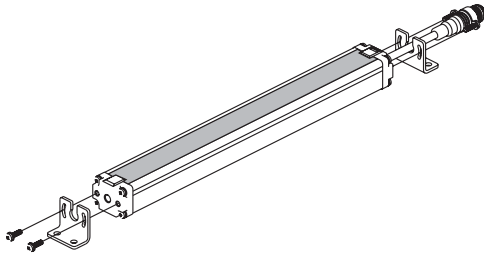

Optical axis pitch/Number of optical axis/Sensing height

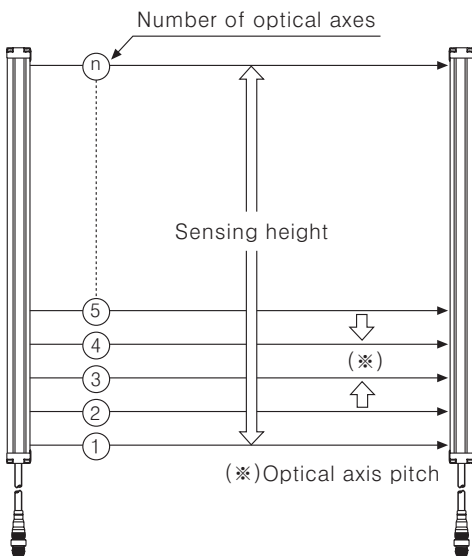

Model	Optical axis pitch
BW20-□□(P)	20mm
BW40-□□(P)	40mm

Model	Number of optical axis	Sensing height	Model	Number of optical axis	Sensing height
BW20-08(P)	8	140mm	BW40-04(P)	4	120mm
BW20-12(P)	12	220mm	BW40-06(P)	6	200mm
BW20-16(P)	16	300mm	BW40-08(P)	8	280mm
BW20-20(P)	20	380mm	BW40-10(P)	10	360mm
BW20-24(P)	24	460mm	BW40-12(P)	12	440mm
BW20-28(P)	28	540mm	BW40-14(P)	14	520mm
BW20-32(P)	32	620mm	BW40-16(P)	16	600mm
BW20-36(P)	36	700mm	BW40-18(P)	18	680mm
BW20-40(P)	40	780mm	BW40-20(P)	20	760mm
BW20-44(P)	44	860mm	BW40-22(P)	22	840mm
BW20-48(P)	48	940mm	BW40-24(P)	24	920mm

Timing diagram of operation

●Operation mode : Light ON

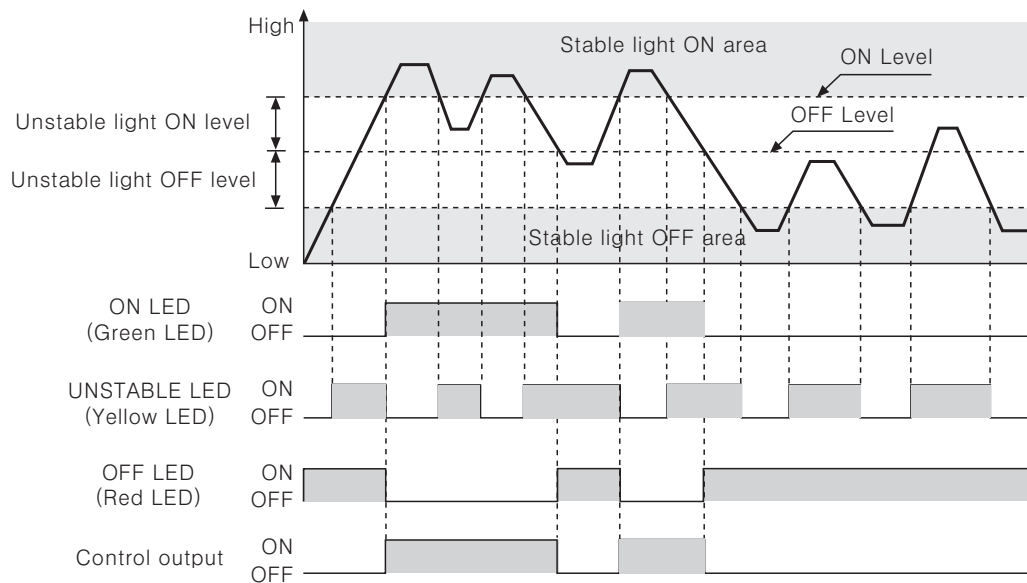

(A) Counter

(B) Timer

(C) Temp. controller

(D) Power controller

(E) Panel meter

(F) Tacho/Speed/Pulse meter

(G) Display unit

(H) Sensor controller

(I) Switching power supply

(J) Proximity sensor

(K) Photo electric sensor

(L) Pressure sensor

(M) Rotary encoder

(N) Stepping motor & Driver & Controller

(O) Graphic panel

(P) Production stoppage models & replacement

BW Series

Function

Stop transmission function (External diagnosis function)

The transmission will be stopped and yellow LED is flashed if supplying 0V to test input on the emitter. It is for checking malfunction of the sensors during TEST input on the emitter is 0V. (Control output of the receiver is OFF as it becomes light cut off when the transmission is stopped.)

Connections for TEST input

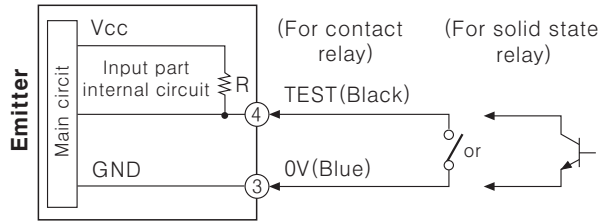

Control output pulse by TEST input

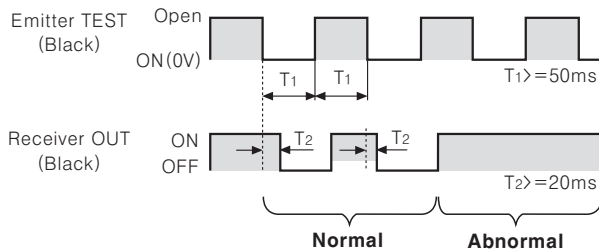

Self-diagnosis function

Control output will be OFF and operating indicator is ON when malfunction is checked by self-diagnosis regularly in normal operation.

Diagnosis items

- Emitter : ① Break of light emitting element
② Break of light emitting circuit
③ Malfunction of MASTER/SLAVE line (Operation in MASTER)
- Receiver : ① Break of light receiving circuit
② Break of output circuit
③ Overcurrent at output part
④ Synchronous line malfunction
⑤ Extraneous light received

Refer to K-72, "Operation indicator" for the display operation of diagnosis.

Interference protection function

2 sensors are used in parallel in order to extend sensing width, the detection will be failure because as light interference.

This function is to avoid the light interference as operating a sensor in MASTER and another sensor in SLAVE to protect these kinds of failures.

Time chart for MASTER/SLAVE transmission pulse

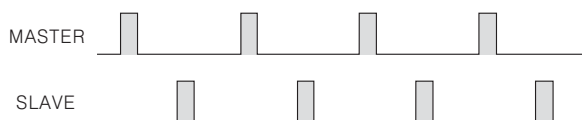

MASTER/SLAVE connections

<NPN open collector output >

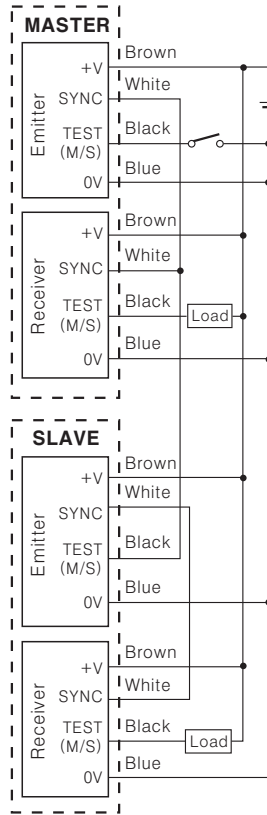

<PNP open collector output >

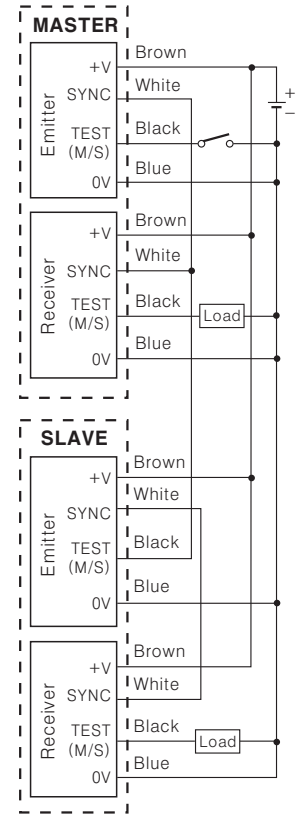

Installation

For direction of installation

Emitter and receiver should be installed in same up/down direction.

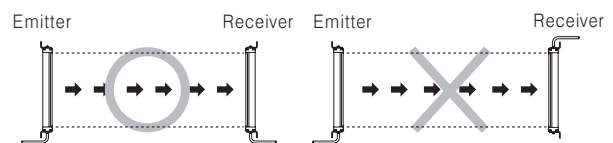

For reflection from the surface of wall and flat

When installing it as below the light reflected from the surface of wall and flat will not be shaded. Please, check whether it operates normally or not with a sensing target before using. (Interval distance : Min. 0.5m)

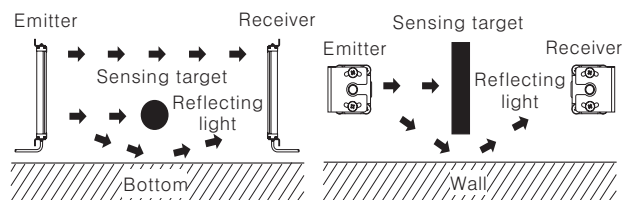

For prevention of interference

It may cause interference when installing more than 2 sets of the sensor. In order to avoid the interference of the sensor, please install as following figures and use the interference protection function.

Area Sensor

<Light emitting direction should be opposite between 2 sets >

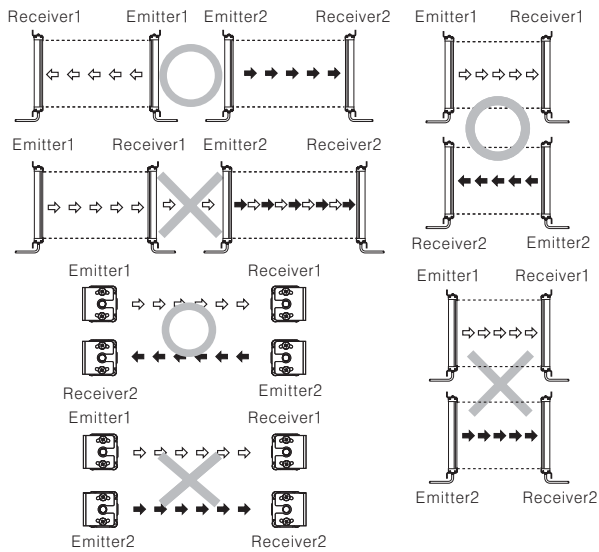

<Shield panel should be installed between 2 sets >

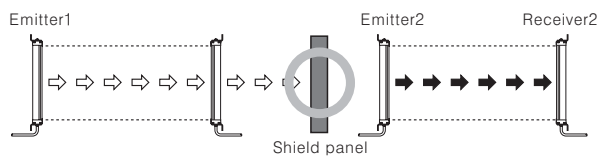

<It should be installed out of the installation allowable distance >

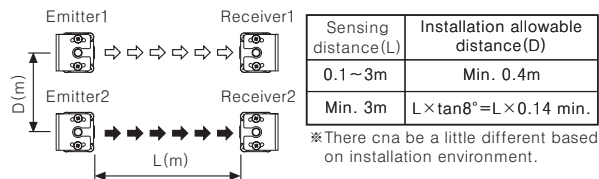

Operation indicator

Item	Emitter		Receiver			Control output
	Indicator	Indicator	Indicator	Indicator	Indicator	
Power supply	☀	●	—	—	—	—
MASTER operation	☀	●	—	—	—	—
SLAVE operation	☀	☀	—	—	—	—
Test input	☀	◐	—	—	—	—
Break of light emitting element	◐	◑	—	—	—	OFF
Break of light emitting circuit	◐	◑	—	—	—	OFF
Stable light ON	—	—	☀	●	●	ON
Unstable light ON	—	—	☀	☀	●	ON
Unstable light OFF	—	—	●	☀	☀	OFF
Stable light OFF	—	—	●	●	☀	OFF
Break of light receiving circuit	—	—	●	◐	◑	OFF
Break of output element	—	—	◐	◑	●	OFF
Synchronous line malfunction	—	—	◐	●	◑	OFF
Overcurrent	—	—	◐	◐	◐	OFF
Extraneous light received	—	—	●	◐	◑	OFF
Breakdown of emitter	—	—	◐	◐	◐	OFF

Display classification list	
☀	Light on
●	Light off
◐	Flashing by 0.5 sec.
◐◐ or ◐◑◐	Flashing simultaneously by 0.5 sec.
◐◑	Cross-Flashing by 0.5 sec.
◐◐◐	Sequence-Flashing by 0.5 sec.

Inspection/Solution for malfunction

Malfunction	Caution	Solution
Non-operation	Power	Supply rated power
	Cable disconnection, incorrect connection	Check the wiring
	Rated connection failure	Use within rated sensing distance
Non-operation in sometimes	Pollution by dirt of sensor cover	Remove dirt by soft brush or cloth
	Connector connection failure	Check the assembled part of the connector
Control output is OFF even though there is not a target object.	Out of rated sensing distance	Use within rated sensing distance
	There is an obstacle to cut off the light emitted between emitter and receiver	Remove the obstacle
	There is a strong electric wave or noise generated by motor, electric generator, high voltage line etc.)	Put away the strong electric wave or noise generator.
LED display for break of light emitting element	Damage on light emitting element	Contact our company
LED display for break of light emitting circuit	Damage on light emitting circuit	
LED display for break of light receiving element	Damage on light receiving element	
LED display for break of output element	Damage on output element	
LED display for synchronous line malfunction	Synchronous line incorrect connection or disconnection	Check the wiring
	Damage on synchronous circuit of emitter or receiver	Contact to our company
LED display for over current	Control output line shorted	Check the wiring
LED display for ambient light receiving	Over load	Check the rated load capacity
	Extraneous light received to receiver	Remove the extraneous light
LED displayed for emitter malfunction	Emitter malfunction	Treat after checking the emitter display LED

- (A) Counter
- (B) Timer
- (C) Temp. controller
- (D) Power controller
- (E) Panel meter
- (F) Tacho/Speed/Pulse meter
- (G) Display unit
- (H) Sensor controller
- (I) Switching power supply
- (J) Proximity sensor
- (K) Photo electric sensor
- (L) Pressure sensor
- (M) Rotary encoder
- (N) Stepping motor & Driver & Controller
- (O) Graphic panel
- (P) Production stoppage models & replacement